

REFERENCE	BT_2013_X98CUP_09_UK
DATE	2013 July 8th
SUBJECT	Evolutions for the Eurocup Clio Red Bull Ring meeting (2/2)

CONCERNED : 2013 EURO CUP CLIO

Dear Competitors,

Following the Technical Bulletin n°8 sent last week, please find a list of updates / evolutions for the Red Bull Ring meeting.

1) Gearbox command

As mentioned in the Technical Bulletin n°8 from last week, SADEV will send you back the updated parts (rocker + actuator yoke) but **only the rocker has been updated.**

For a correct use of the new system, you need to slightly **modify your own actuator yoke**. This update consists in drilling and tapping a M3 hole for the indexing of the new interface ring in the actuator yoke, as indicated below :

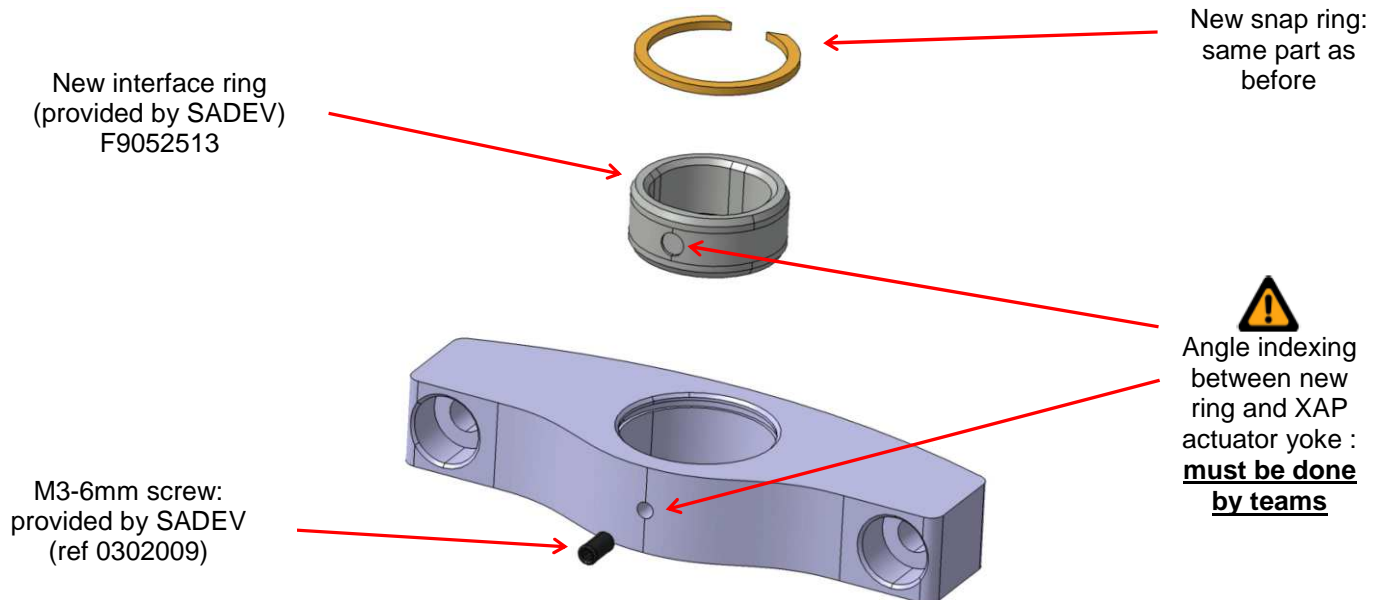

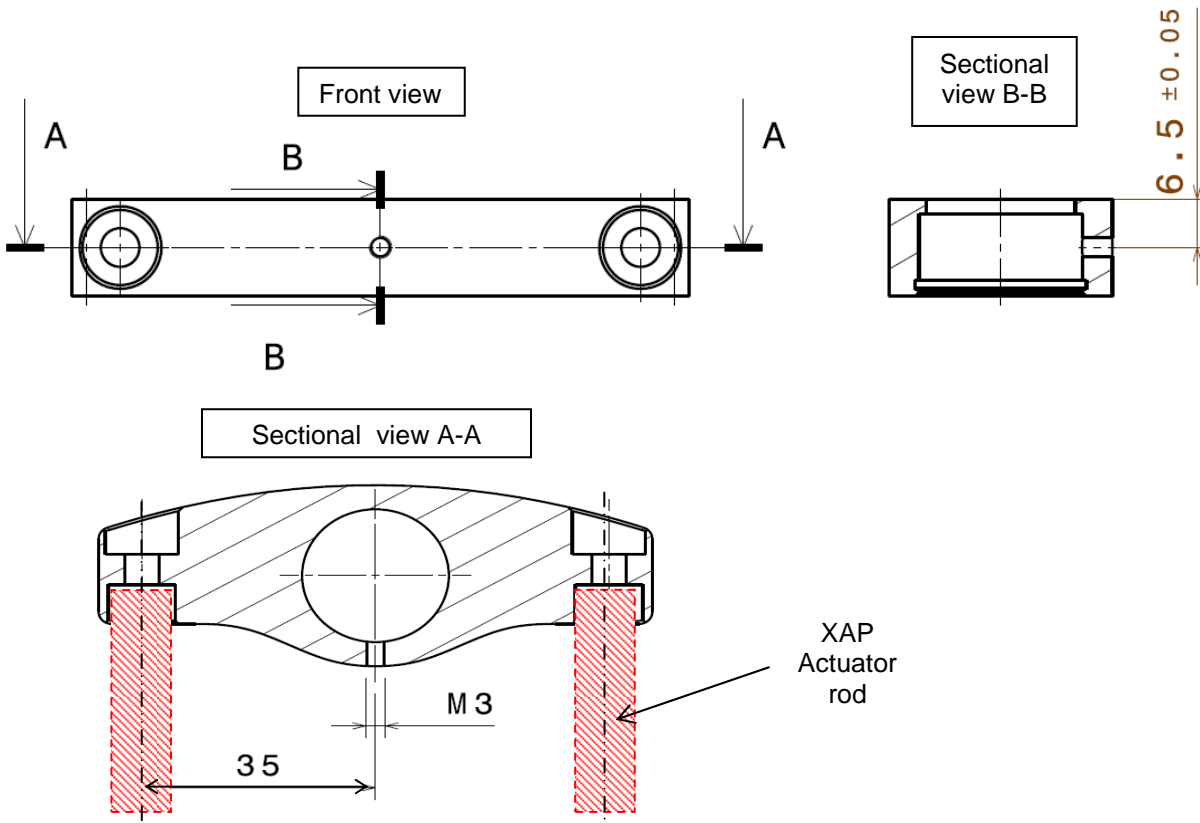

NOTE :

- This M3 hole has to be done **very precisely** to ensure a good indexing of the new ring
- If you don't receive your updated kit before the end of this week, RENAULT SPORT will bring all the parts directly to the Red Bull Ring (agreement RENAULT SPORT / SADEV)
- This update is not mandatory for the Red Bull Ring but it will be mandatory for Paul Ricard meeting

2) Accessory belt protection

We inform you that Renault Sport is working on a protective cover for the accessory belt. A test will be done on 2 cars during Friday collective test in Red Bull Ring but the solution can't be applied before the Paul Ricard meeting in september.

Waiting for this date, a provisory engine protection lower cover will be provided free of charge under the reference: 77 11 162 473

Some modifications have to be performed prior to fit it under the subframe :

1) Cut the part as indicated below:

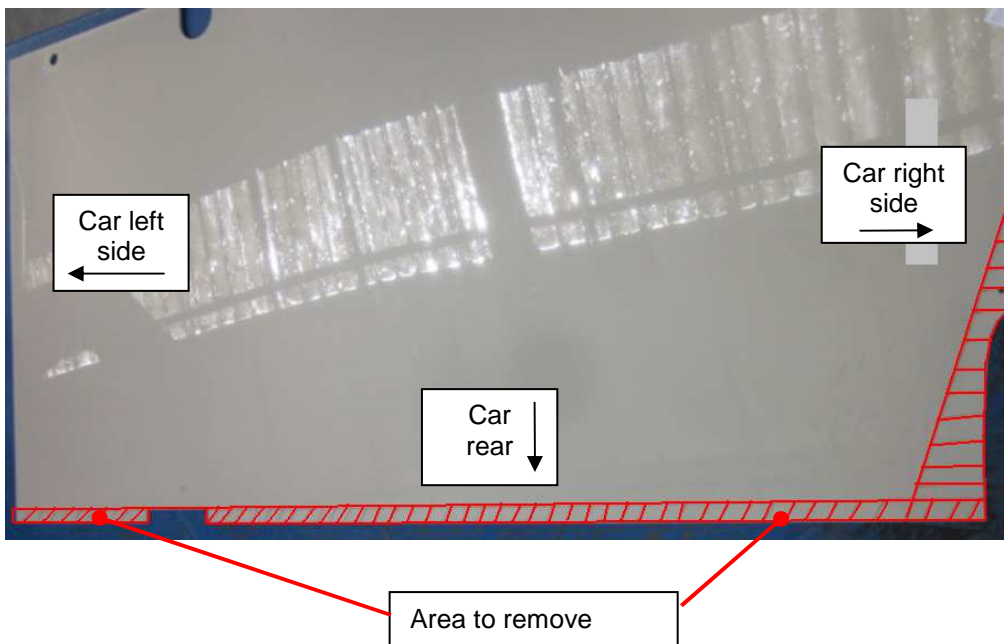
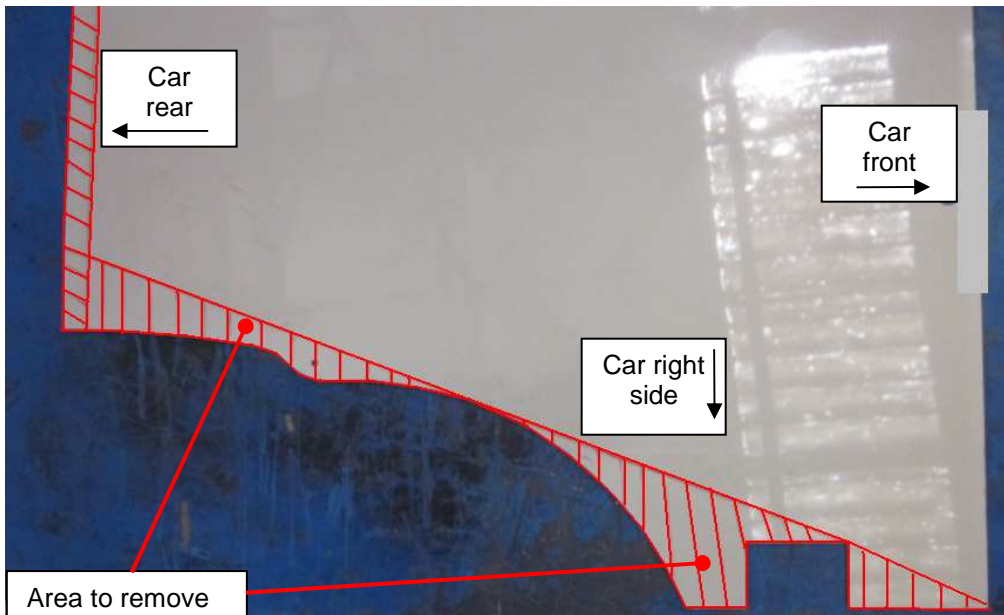

2) Drill 2 holes Ø8mm (holes n° 4 and 5) at the following positions:

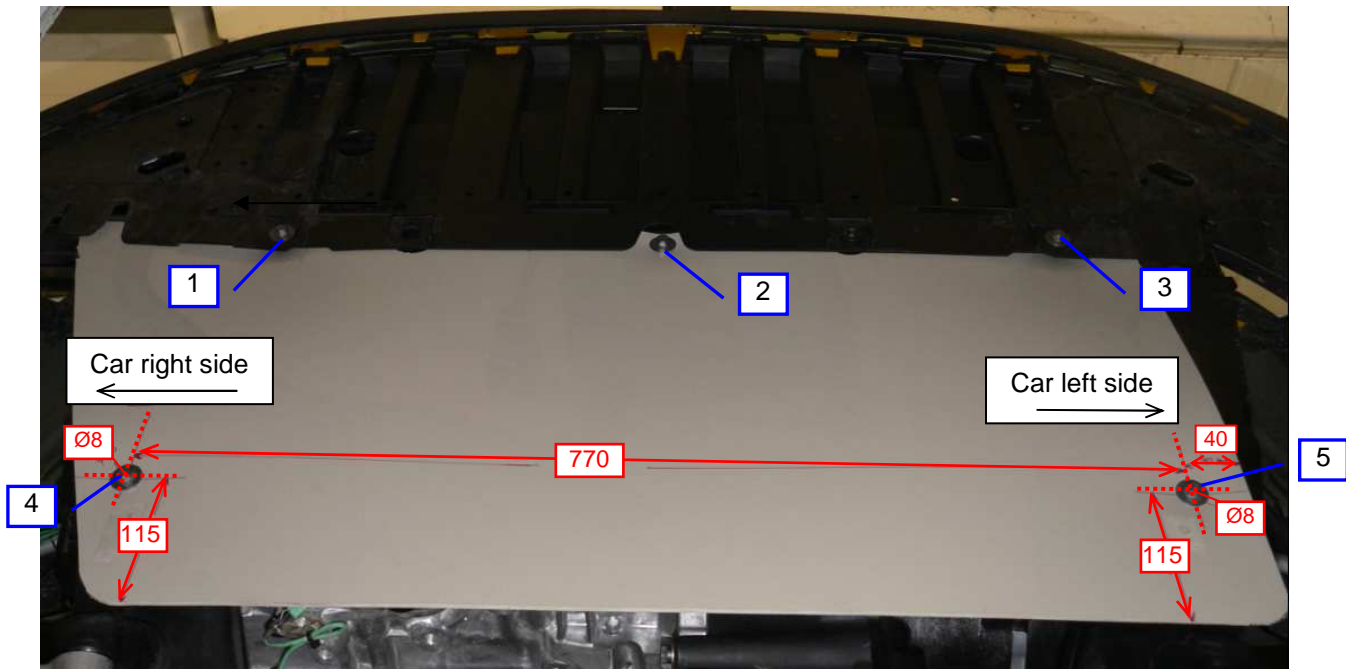

Picture 1 : View from below

3) This lower cover has to be fitted using 5 HH screws reference: 77 03 602 059 (M6-30) as indicated on **Picture 1**

NOTE :

All fastening point are situated on the front shock absorber (544F04040R) :

